



OPERATIONS MANUAL

*TE-1000BL PUF Poly-Urethane Foam
High Volume Air Sampler*

**Tisch Environmental, Inc.
145 South Miami Avenue
Village of Cleves, Ohio 45002**

Toll Free: (877) 263 -7610 (TSP AND-PM10)

Direct: (513) 467-9000

FAX: (513) 467-9009

sales@tisch-env.com

www.tisch-env.com



TE-1000BL PUF

Welcome

We are the experts in high volume air sampling, lead sampling, lead samplers, particulate monitoring, particulate emissions, pesticide monitoring, pesticide sampling, total suspended particles, particulate sampler, Federal Reference Method PM-10, Federal Reference Method PM2.5, EPA Method TO-4A, EPA Method TO-9A, EPA Method TO-13A. TEI is a family business located in the Village of Cleves, Ohio. TEI employs skilled personnel who average over 20 years of experience each in the design, manufacture, and support of air pollution monitoring equipment. Our modern well-equipped factory, quality philosophy and experience have made TEI the supplier of choice for air pollution monitoring equipment. Now working on the fourth generation, TEI has state-of-the-art manufacturing capability and is looking into the future needs of today's environmental professionals.

Assistance

If you encounter problems or require detailed explanations, do not hesitate to contact Tisch Environmental offices by e-mail or phone.

Toll Free: (877) 263 -7610 (TSP AND-PM10)

Direct: (513) 467-9000

FAX: (513) 467-9009

sales@tisch-env.com

www.Tisch-Env.com

Table of Contents

Welcome	3
Assistance	3
Introduction	6
EPA Standards	6
Safety Precautions	6
Important Safety Instructions	6
Electrical Installation	7
Do Not Abuse Cords	7
Extension Cords	7
Product Description	8
Introduction	8
Applications	9
Calibration Requirements	9
Parts	10
Assembly	12
Gabled Roof Assembly	13
Electrical Set-Up	15
Operations	16
Calibration Procedure	16
Example Problems	19
Unit Operation	25
Sampling Module	26
Sorbents	27
Determination of Flow Rate	28
Troubleshooting	29
Maintenance and Care	31
Warranty	32

<i>Assembly Drawings</i> _____	33
TE-1002 Particulate/Vapor Module _____	33
TE-1004-BL Blower Motor Assembly _____	34
<i>Calibrator Certificate</i> _____	35
<i>Calibration Worksheet</i> _____	36

Introduction

EPA Standards

The following manual will instruct you in the unpacking, assemblage, operation, calibration, and usage of the corresponding Tisch Environmental product. For information on air sampling principles, procedures and requirements and to ensure compliance with government regulations please contact the local Environmental Protection Agency Office serving your area or visit www.epa.gov.

Safety Precautions

Before using Tisch Environmental products, always be sure to review the corresponding operations manuals and take all necessary safety precautions. Tisch Environmental products are to be used only for the purposes specified by operations manuals and by Tisch Environmental personnel. Tisch Environmental cannot guarantee the safe usage of its instruments in procedures that do not adhere to Tisch Environmental guidelines and standards. If you have concerns about the safety of your product or questions about safe practices, contact Tisch Environmental by phone or e-mail to speak with a representative.

Important Safety Instructions

Read and understand all instructions. Do not dispose of these instructions. Failure to follow all instruction listed in this manual may result in electric shock, fire, and/or personal injury. When using an electrical device, basic precautions must always be followed, including the precautions listed in the safety section of this manual. Never operate this unit in the presence of flammable materials or vapors are present as electrical devices may produce arcs or sparks that can cause fire or explosions. Always disconnect power supply before attempting to service or remove any components. Never immerse electrical parts in water or any other liquid. Always avoid body contact with grounded surfaces when plugging or unplugging this device is wet or dangerous conditions.

Electrical Installation

Installation must be carried out by specialized personal only, and must adhere to all local safety rules. This unit can be used for different power supply versions; before connecting this unit to the power line, always check if the voltage shown on the serial number tag corresponds to the one on your power supply. This product does use grounded plugs and wires. Grounding provides the path of least resistance for electrical currents, thereby reducing the risk of electric shock to users. This system is equipped with electrical cords with internal ground wires and a grounding plug. The plug must be plugged into a matching outlet that is properly installed and grounded in accordance with all local codes and ordinances. Do not modify the plug provided. If plug will not fit outlet, have the proper corresponding outlet installed by a professional, qualified electrician.

Do Not Abuse Cords

In the event that any electrical component of this system needs to be transported, **DO NOT** carry the unit by its power cord or unplug the unit by yanking the cord from the outlet. **Pull the plugs, not the cords**, to reduce risk of damage to unit. Keep all cords away from heat, oil, sharp objects, and moving parts.

Extension Cords

It is always advisable to use the shortest extension cord possible. Grounded units require a three-wire extension cord. As the distance from the supply outlet increases, you must use a heavier gauge extension cord. Using extension cords with inadequately sized wires results in serious changes in voltage, resulting in a loss of power and possible damage to equipment. It is recommended to only use 10-gauge extension cords for this product. Never use cords that exceed one hundred feet. Outdoor extension cords must be marked with the suffix "W-A" (or "W" in Canada) to indicate that it is suitable for outdoor usage. Always ensure that extension cords are properly wired and in good electrical condition. Always replace damaged extension cords immediately, or seek repair from qualified electricians before further use. Remember to protect extension cords from sharp objects, excessive heat, and damp or wet conditions.

Product Description

Introduction

TE-1000-BL PUF Poly-Urethane Foam sampler is a complete system designed to simultaneously collect suspended airborne particulates as well as trap airborne pesticide vapors at flow rates up to 280 liters per minute. The TE-PUF features the latest in technological advances for accurately measuring airborne particulates and vapors.

A dual chambered aluminum sampling module contains both filtering systems. The upper chamber supports the airborne particulate filter media in a circular filter holder. The lower chamber encapsulates a glass cartridge which contains the PolyUrethane Foam for vapor entrapment.

A wide variety of sorbents can be used in a manner that permits their continual use. Poly urethane foam or wet/dry granular solid media can be used individually or in combination. The dual chambered sampling module is designed for easy access to both upper and lower media. The threaded lower canister is removed with the cartridge intact for immediate exchange. Filter support screens and module components are equipped with gaskets providing a leak proof seal during the sampling process. Air flow rates are infinitely variable up to 280 liters per minute. The voltage variator adjusting screw alters the blower motor speed to achieve the flow rate desired. Air flow rate is measured through the flow venturi utilizing a 0-100" Magnehelic Gage. Periodic calibration is necessary to maintain on-site sampling accuracy. A Seven Day Mechanical Timer (TE-5007) is included as standard equipment and permits weekly scheduling with individual settings for each day and 14 trippers to turn the sampler On and Off as desired. Any day or days may be omitted. Day and night periods are distinctly marked. Other timers and programmers are available optionally to suit any sampling requirement.

Applications

- ❖ Meets US EPA methods TO-4A, TO-9A, and TO-13A.
- ❖ Samples semi-volatile organic compounds.
- ❖ Especially designed for sampling airborne particulates and vapor contamination from pesticide compounds.
- ❖ Successfully demonstrated to efficiently collect a number of organochlorine and organophosphate pesticides.
- ❖ By-pass blower motor design permits continuous sampling for extended periods at rates to 280 liters per minute.
- ❖ Proven sampler components housed in an anodized aluminum shelter for outdoor service.
- ❖ Samples in accordance with U.S. EPA Method TO-4A, "Method for the Determination of Organochlorine Pesticides and Polychlorinated Biphenyls in Ambient Air using high volume polyurethane foam (PUF) sampler."

Calibration Requirements

The TE-1000-BL PUF Sampler should be calibrated:

- Upon installation
- After motor maintenance
- At least once every three months
- After 360 sampling hours

Parts

1. Shelter Box - 48" x 20" x 20" 74 lbs

PUF Sampler System

TE-1000BL 110volt, 60hz

TE-1000-BLX 220volt, 50hz

TE-1000-BLXZ 220volt, 60hz



7-Day Mechanical Timer

TE-5007 110volt, 60hz

TE-5007X 220volt, 50hz

TE-5007XZ 220volt, 60hz



Flow Venturi & Calibration Valve

TE-1003



Motor Voltage Control

TE-5010-BL 110volt, 60hz

TE-5010-BLXX 220volt, 50hz

TE-5010-BLXZ 220volt, 60hz



PUF Blower Motor Assembly
TE-1004BL 110volt
TE-1004-BLX 220volt



Dual Sampling Module
TE-1002



Exhaust Hose
TE-1023



Magnehelic Gauge
TE-1005



2. Lid Box - 19" x 14" x 14" 9 lbs

Gabled Roof
TE-5001-10









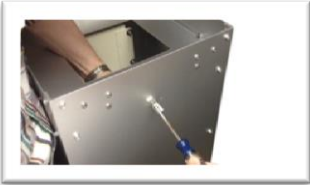

***** Save the shipping containers and packing material for future use.**

Assembly

1. Open shelter box and remove the Anodized Aluminum Shelter.
2. Enclosed in the 13" x 10" x 7" box on the bottom of the shelter is the TE-1002 Dual Sampling Module. Remove it from the box.
3. Take out the rubber plug that is in the quick disconnect on shelter. Insert Dual Sampling Module and lock in place by pushing rings down to seal tightly.
4. Take of the cover that is on top of the 4" filter holder. Turning motor on with cover in place will damage motor.
5. Open lid box and remove 5001-10 roof.
6. Inside of the shelter is the exhaust hose. Unwrap and insert end with speed clamp on end of blower motor discharge. Tighten with a flat edge screwdriver and put end of hose downwind of sampler.

Gabled Roof Assembly

<p><u>Lid Hardware</u> 5 pcs 10-24 x 1/2 pan head screws 5 pcs 10-24 stop nuts 1 pc 6-32 x 3/8 pan head screw 1 pc 6-32 hex nut 1 pc 20" chain with "S" hook 1 pc TE-5001-10-9 roof back catch 1 pc TE-5001-10-10 front catch 1 pc TE-5001-10-11 rear lid hasp</p>	
<p><u>Step 1</u> Secure TE-5001-10-10 front catch to the shelter using 2 10-24 pan head screws with stop nuts. <i>*Do not tighten completely, this may need to be adjusted after final assembly*</i></p>	
<p><u>Step 2</u> Secure TE-5001-10-9 roof back catch to the back of shelter using #6-32 pan head screw with stop nut.</p>	
<p><u>Step 3</u> Secure TE-5001-10-11 rear lid hasp inside the lid with the slot angled up using (2) #10-24 pan head screws with stop nuts. <i>*Do not tighten completely, this may need to be adjusted after final assembly*</i></p>	
<p><u>Step 4</u> Remove (4) #10-24 x 1/2" pan head screws from the rear of the shelter, attach the lid to the shelter by placing the lid hinge plates on the "OUTSIDE" of the shelter, line the hinges up with the (4) threaded holes in the back of the shelter. Use the (4) #10-24X 1/2" pan head screws that were removed previously to attach the lid hinges to the shelter. <i>*Tighten completely*</i></p>	

<p><u>Step 5</u> Adjust the front and rear catch to be sure that the lid slots lowers over it when closing. Tighten the roof back hasp and front catch completely.</p>	
<p><u>Step 6</u> Attach the chain and “S” hook assembly to the side of the shelter with a #6-32 x 3/8” pan head screw.</p>	
<p><u>Step 7</u> The Lid can now be secured in an open or closed position with the “S” hook.</p>	

Electrical Set-Up

TE-1000 BL Electrical Set-Up

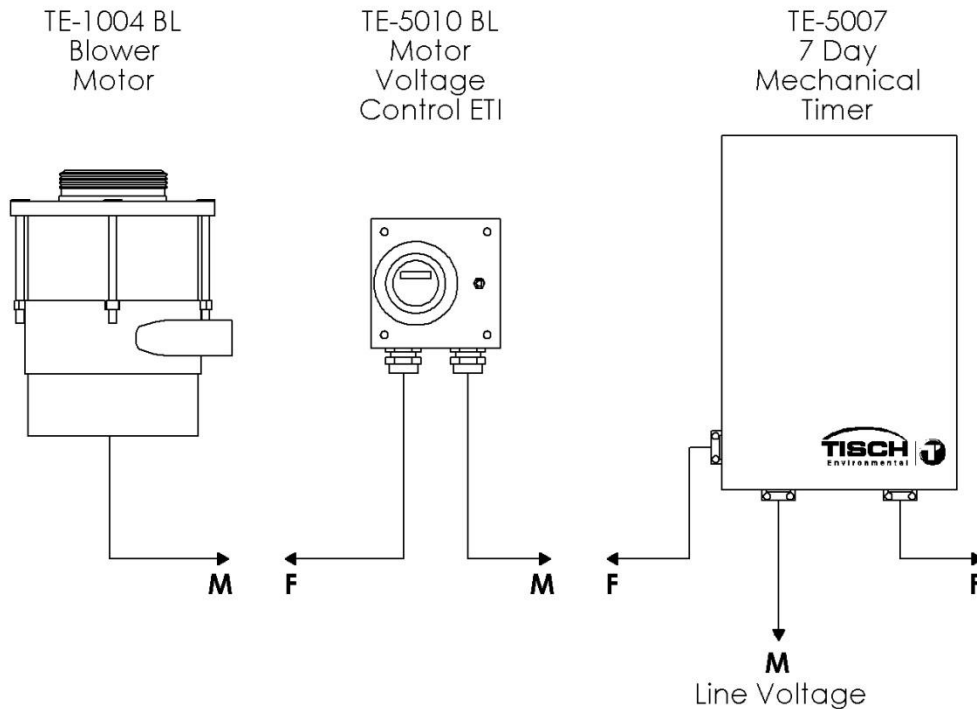

1. The TE-1004BL Brushless PUF Blower Motor male cord set plugs into the TE-5010BL Motor Voltage Control Female cord set.
2. The male cord set of the Motor Voltage Control plugs into the TE-5007 7-Day Mechanical Timer timed female cord set which is on the left side of timer.
3. The other female cord set on timer (on the right) is hot all the time and is an extra plug.
4. The male cord set of timer plugs into the line voltage.

Operations

Calibration Procedure

Visit, www-tisch-env.com/calibration-worksheets, to download calibration worksheets. The calibration worksheets allow the user to input the data and automatically make the calculations. The manual calculation method is described in the following sections for your reference, however, it is highly recommended to download the calibration worksheets.

Proceed with the following steps to begin the calibration:

1. Calibration of the PUF Sampler is performed without a foam plug (TE-1010) or filter paper in the sampling module. However the empty glass cartridge must remain in the module to insure a good seal through the module.
2. Install the TE-5040A Calibrator (orifice) on top of the 4" Filter Holder. Tighten and make sure of no leaks.
3. Open both ports on top of manometer and connect tubing from manometer port to the pressure tap on the TE-5040A Calibrator. Leave the opposite side of manometer port open to the atmosphere.
4. Open ball valve fully (handle should be straight up), this is located inside of shelter directly above the blower motor.
5. Turn the system on by tripping the manual switch on the timer. Allow a few minutes for motor to warm-up.
6. Adjust and tighten the voltage control screw (variac) on the TE-5010 to obtain a reading of 70 inches on the dial of the Magnehelic Gage (or 80 whatever is desired). Do not change until completion of calibration.
7. With 70 inches on the gage as your first calibration point, record this figure and the orifice manometer reading on your data sheet. To read a manometer one side goes up and one goes down, add both sides together, this is your inches of water.
8. Close the ball valve slightly to readjust the dial gage down to 60 inches. Record this figure and the orifice manometer reading on your data sheet.

9. Using the above procedure, adjust the ball valve for readings at 50, 40, and 30 inches and record on data sheet. You should have 5 sets of numbers 10 numbers in all.
10. Manually turn sampler off.

To download the calibration worksheet please visit, www.tisch-env.com/calibration-worksheets and select the “TE-1000 PUF calibration worksheet.”. An example of a TE-1000-BL PUF Sampler Calibration Data Sheet has been attached with data filled in from a typical calibration. This includes the transfer standard orifice calibration relationship which was taken from the Orifice Calibration Worksheet that accompanies the calibrator orifice. Since this calibration is for a PUF sampler, the slope and intercept for this orifice uses **standard** flows rather than actual flows.

The five orifice manometer readings taken during the calibration have been recorded in the column on the data worksheet titled H₂O (in). The five Magnehelic Gage readings taken during the calibration have been recorded under the column titled FLOW (magn).

The orifice manometer readings need to be converted to the standard air flows they represent using the following equation:

$$Q_{std} = 1/m[\text{Sqrt}((H_2O)(Pa/760)(298/Ta))-b]$$

where:

Q_{std} = actual flow rate as indicated by the calibrator orifice, m³/min

H₂O = orifice manometer reading during calibration, in. H₂O

T_a = ambient temperature during calibration, K (K = 273 + C°)

298 = standard temperature, a constant that never changes, K

Pa = ambient barometric pressure during calibration, mm Hg

760 = standard barometric pressure, a constant that never changes, mm Hg

m = *Q*_{standard slope of orifice} calibration relationship

b = *Q*_{standard intercept of orifice} calibration relationship.

Once these standard flow rates have been determined for each of the five run points, they are recorded in the column titled Q_{std}, and are represented in cubic meters per minute.

The Magnehelic Gage readings taken during the calibration need to be corrected to the current meteorological conditions using the following equation:

$$\text{FLOW (corrected)} = \text{Sqrt}((\text{magn})(\text{Pa}/760)(298/\text{Ta}))$$

where:

FLOW (corrected) = Magnehelic Gage readings corrected to current Ta and Pa

magn = Magnehelic Gage readings during calibration

Pa = ambient barometric pressure during calibration, mm Hg

760 = standard barometric pressure, a constant, mm Hg

Ta = ambient temperature during calibration, K (K = 273 + C°)

298 = standard temperature, a constant, K

After each of the Magnehelic Gage readings have been corrected, they are recorded in the column titled FLOW (corrected).

Using Qstd and FLOW (corrected) as the x and y axis respectively, a slope, intercept, and correlation coefficient can be calculated using the least squares regression method. The correlation coefficient should never be less than 0.990 after a five point calibration. A coefficient below .990 indicates a calibration that is not linear and the calibration should be performed again. If this occurs, it is most likely the result of an air leak during the calibration.

The equations for determining the slope (m) and intercept (b) are as follows:

$$m = \frac{\sum xy - \frac{(\sum x)(\sum y)}{n}}{\sum x^2 - \frac{(\sum x)^2}{n}} ; \quad b = \bar{y} - m\bar{x}$$

where: n = number of observations

$\bar{y} = \sum y/n$; $\bar{x} = \sum x/n$

\sum = sum of

The equation for the coefficient of correlation (r) is as follows:

$$r = \frac{\sum xy - \frac{(\sum x)(\sum y)}{n}}{\sqrt{\left[\sum x^2 - \frac{(\sum x)^2}{n}\right] \left[\sum y^2 - \frac{(\sum y)^2}{n}\right]}}$$

where: n = number of observations
 \sum = sum of

If you wanted to set this sampler at .242 m³/min (8.5 CFM or 242 LPM) (Make sure the ball valve is open fully, a 4" filter is in place, and the module is loaded) you would turn the voltage control screw or variac until the Magnehelic Gage read 60 inches. By making sure that the sampler is operating at a Magnehelic Gage reading that is within the acceptable range, it can be assumed that valid PUF data is being collected.

Example Problems

The following problem uses data from the attached calibration worksheet and calibrator certificate.

After all the sampling site information, calibrator information, and meteorological information have been recorded on the worksheet, standard air flows need to be determined from the orifice manometer readings taken during the calibration using the following equation:

$$1. Q_{std} = 1/m[\text{Sqrt}((H_2O)(Pa/760)(298/Ta))-b]$$

where:

Q_{std} = actual flow rate as indicated by the calibrator orifice, m³/min

H₂O = orifice manometer reading during calibration, in. H₂O

T_a = ambient temperature during calibration, K (K = 273 + C°)

298 = standard temperature, a constant that never changes, K

Pa = ambient barometric pressure during calibration, mm Hg

760 = standard barometric pressure, a constant that never changes, mm Hg

m = Q_{standard} slope of orifice calibration relationship

b = Q_{standard} intercept of orifice calibration relationship.

Note that the ambient temperature is needed in degrees Kelvin to satisfy the Qstd equation. Also, the barometric pressure needs to be reported in millimeters of mercury. In our case the two following conversions may be needed:

2. **degrees Kelvin = $[5/9 (\text{degrees Fahrenheit} - 32)] + 273$**
3. **millimeters of mercury = $25.4(\text{inches of H}_2\text{O}/13.6)$**

Inserting the numbers from the calibration worksheet run point number one we get:

4. $Qstd = 1/9.82823[\text{Sqrt}((7.5)(756.9/760)(298/294.8)) - (-.03871)]$
5. $Qstd = .1017477[\text{Sqrt}((7.5)(.996)(1.011)) + .03871]$
6. $Qstd = .1017477[\text{Sqrt}(7.55217) + .03871]$
7. $Qstd = .1017477[2.7481211 + .03871]$
8. $Qstd = .1017477[2.7868311]$
9. $Qstd = .284$

Throughout these example problems you may find that your answers vary some from those arrived at here. This is probably due to different calculators carrying numbers to different decimal points. The variations are usually slight and should not be a point of concern.

With the Qstd determined, the corrected Magnehelic Gage reading FLOW (corrected) for this run point needs to be calculated using the following equation:

$$10. \text{FLOW (corrected)} = \text{Sqrt}((\text{magn})(\text{Pa}/760)(298/\text{Ta}))$$

where:

FLOW (corrected) = Magnehelic Gage readings corrected to standard

magn = Magnehelic Gage readings during calibration

Pa = ambient barometric pressure during calibration, mm Hg.

760 = standard barometric pressure, mm Hg

Ta = ambient temperature during calibration, K (K = 273 + C°)

298 = standard temperature, K.

Inserting the data from run point one on the calibration worksheet we get:

11. $\text{FLOW (corrected)} = \text{Sqrt}((70)(756.9/760)(298/294.8))$
12. $\text{FLOW (corrected)} = \text{Sqrt}((70)(.996)(1.011))$

13. FLOW (corrected) = Sqrt(70.48692)
 14. FLOW (corrected) = 8.39

This procedure should be completed for all five run points.

Using Qstd as our x-axis, and FLOW (corrected) as our y-axis, a slope, intercept, and correlation coefficient can be determined using the least squares regression method.

The equations for determining the slope (m) and intercept (b) are as follows:

$$15. \quad m = \frac{\frac{(\sum x)(\sum y)}{n} - \frac{\sum xy}{n}}{\frac{(\sum x)^2}{n} - \sum x^2} \quad ; \quad b = \bar{y} - m\bar{x}$$

where: n = number of observations
 $\bar{y} = \sum y/n$; $\bar{x} = \sum x/n$
 \sum = sum of.

The equation for the coefficient of correlation (r) is as follows:

$$16. \quad r = \frac{\frac{(\sum x)(\sum y)}{n} - \frac{\sum xy}{n}}{\sqrt{\left[\frac{(\sum x)^2}{n} - \sum x^2 \right] \left[\frac{(\sum y)^2}{n} - \sum y^2 \right]}}$$

where: n = number of observations
 \sum = sum of

Before these can be determined, some preliminary algebra is necessary. $\sum x$, $\sum y$, $\sum x^2$, $\sum xy$, $(\sum x)^2$, $(\sum y)^2$, n, \bar{y} , and \bar{x} need to be determined.

17. $\sum x = .284 + .266 + .249 + .230 + .200 = 1.229$
 18. $\sum y = 8.39 + 7.77 + 7.09 + 6.35 + 5.50 = 35.1$
 19. $\sum x^2 = (.284)^2 + (.266)^2 + (.249)^2 + (.230)^2 + (.200)^2 = .306313$
 20. $\sum y^2 = (8.39)^2 + (7.77)^2 + (7.09)^2 + (6.35)^2 + (5.50)^2 = 251.6056$

$$21. \quad \Sigma xy = (.284)(8.39) + (.266)(7.77) + (.249)(7.09) + (.230)(6.35) + (.200)(5.50) = 8.77549$$

$$22. \quad n = 5$$

$$23. \quad \bar{x} = \Sigma x/n = .2458$$

$$24. \quad \bar{y} = \Sigma y/n = 7.02$$

$$25. \quad (\Sigma x)^2 = (1.229)^2 = 1.510441$$

$$26. \quad (\Sigma y)^2 = (35.1)^2 = 1232.01$$

Inserting the numbers:

$$27. \text{ slope} = \frac{8.77549 - \frac{(1.229)(35.1)}{5}}{306313 - \frac{1.510441}{5}}$$

$$28. \text{ slope} = \frac{8.77549 - \frac{43.1379}{5}}{.306313 - \frac{1.510441}{5}}$$

$$29. \text{ slope} = \frac{8.77549 - 8.62758}{.306313 - 0.302}$$

$$30. \text{ slope} = \frac{.14791}{.004313}$$

$$31. \text{ slope} = 34.293994$$

$$32. \text{ intercept} = 7.02 - (34.293994)(.2458)$$

$$33. \text{ intercept} = 7.02 - 8.4294637$$

$$34. \text{ intercept} = -1.4094637$$

$$35. \text{ correlation coeff.} = \frac{8.77549 - \frac{(1.229)(35.1)}{5}}{\sqrt{\left[.306313 - \frac{(1.229)^2}{5}\right] \left[251.6056 - \frac{(35.1)^2}{5}\right]}}$$

$$36. \text{ correlation coeff.} = \frac{8.77549 - \frac{(43.1379)}{5}}{\sqrt{[(.306313 - .3020882)] [(251.6056 - 246.402)]}}$$

$$37. \text{ correlation coeff.} = \frac{(8.77549 - 8.62758)}{\sqrt{[(.306313 - .3020882)] [(251.6056 - 246.402)]}}$$

$$38. \text{ correlation coeff.} = \frac{.14791}{\sqrt{(.0042248)(5.2036)}}$$

$$39. \text{ correlation coeff.} = \frac{.14791}{\sqrt{.0219841}}$$

$$40. \text{ correlation coeff.} = \frac{.14791}{.1482703}$$

$$41. \text{ correlation coeff.} = .9975699$$

A calibration that has a correlation coefficient of less than .990 is not considered linear and should be re-calibrated. Since the correlation coeff. is > .990 , we have a good calibration.

Unit Operation

1. The PUF Sampler may be operated at ground level or on roof tops. In urban or congested areas, it is recommended that the sampler be placed on the roof of a single story building. The sampler should be located in an unobstructed area, at least two meters from any obstacle to air flow. The exhaust hose should be stretched out in a down wind direction if possible.
2. The sampler should be operated for 24 hours in order to obtain average daily levels of airborne pesticides.
3. On and off times and weather conditions during sampling periods should be recorded. Air concentrations may fluctuate with time of day, temperature, humidity, wind direction and velocity and other climatological conditions.
4. Magnehelic Gage readings should be taken at the beginning and end of each sampling period to obtain an average magnehelic gage reading.

Sampling Module

1. Release the three (3) swing bolts on the 4" filter holder (FH-2104) and remove the triangle cover (cover must be off when sampler is "ON") and hold down ring.
2. Install a clean 102mm dia. glass fiber filter on the support screen in between the teflon gaskets and secure it with the hold down ring and swing bolts.
3. Unscrew together the 4" filter holder and the sampling module cap leaving the module tube in place with the glass cartridge exposed.
4. Load the glass cartridge with foam and or foam/granular solids and replace in the module tube. Fasten the glass cartridge with the module cap and 4" filter holder assembly while making sure that the module assembly, 4" filter holder and all fittings are snug.
5. The glass cartridge and glass fiber filter should be removed from the sampler with forceps and clean gloved hands and immediately placed in a sealed container for transport to the laboratory. Similar care should be taken to prevent contamination of the filter paper and vapor trap (foam) when loading the sampler.
6. **It is recommended to have two (2) sampling modules for each sampling system so that filter and foam exchange can take place in the laboratory.**

Sorbents

Two types of sampling media are recommended for use with the PUF Sampler: polyurethane foams and granular solid sorbents. Foams may be used separately or in combination with granular solids. The sorbent may be extracted and reused (after drying) without unloading the cartridge.

1. Polyurethane Foam (PUF):

- Part number TE-1010 three inch plug is recommended. Also available are two inch (TE-1011) and one inch (TE-1012). This type of foam is white and yellows on exposure to light. Color does not effect the collection efficiency of the material.

2. Granular Solids

- Porous (macroreticular) chromatography sorbents recommended. Pore sizes and mesh sizes must be selected to permit air flow rates of at least 200 liters/minute. Approximately 200 g of sorbent is recommended. ***If too much sorbent is used, the sampler flow rate may be affected.*** The granular solids may be sandwiched between two layers of foam, PN: TE-1011, to prevent loss during sampling and extraction.

Determination of Flow Rate

To figure out the total volume of air that flowed through the PUF sampler during your sampling run take a set-up magnehelic gage reading (when you set the sampler up manually turn it on and take a magnehelic gage reading; in our example it should be 60 inches) and a pick-up reading (after the sample has been taken again manually turn sampler on and take a magnehelic gage reading; for our example let's say it read 54 inches). Take $60 + 54 = 114$ $114/2 = 57$ so the magnehelic gage reading you would use is 57 inches. Put that into the formula (on bottom of worksheet):

$$1/m([\text{Sqrt}(\text{magn})(\text{Pav}/760)(298/\text{Tav})] - b)$$

m = sampler slope

b = sampler intercept

magn = average magnehelic gage reading

Tav = daily average temperature

Pav = daily average pressure

Sqrt = square root

Example:

$$m^3/\text{min} = 1/35.3693([\text{Sqrt}(57)(751.3/760)(298/293.2)] - (-1.6711))$$

$$m^3/\text{min} = .0282731 ([\text{Sqrt}(57)(.9885526)(1.016371)] + 1.6711)$$

$$m^3/\text{min} = .0282731 ([\text{Sqrt}(57.269962)] + 1.6711)$$

$$m^3/\text{min} = .0282731 [(7.5676919)] + 1.6711)$$

$$m^3/\text{min} = .0282731 (7.5676919 + 1.6711)$$

$$m^3/\text{min} = .0282731 (9.2387919)$$

$$m^3/\text{min} = .2612092$$

$$\text{lpm} = 261.2092$$

Total liters of air = lpm x 60 x hours that sampler ran

Let's say our sampler ran 23.9 hours

(end ETI reading - start ETI reading)

** Make sure ETI is in hours otherwise convert to hours **

Total liters of air = $261.2092 \times 60 \times 23.9 = 374,573.99$ liters of air

Troubleshooting

note: this is a general troubleshooting guide, not all problem may apply to every sampler

<u>Problem</u>	<u>Solution</u>
Brush Motor Won't Turn On	<ul style="list-style-type: none"> -Check Motor brushes(Change every 500 hours) -Check Motor(Should be replaced after 2 brush changes about 1500 hours) -Check power supply -Ensure that all electrical connections are secure -Make sure timer is on -Make sure flow controller(if applicable) is adjusted properly -Check for loose or damaged wires -Check speed on TE-5010, ensure adjustment screw is turned clockwise to increase motor speed.
Brushless Motor Won't Turn On	<ul style="list-style-type: none"> -Ensure that all electrical connections are secure -Make sure flow controller(if applicable) is adjusted properly -Check power supply -Make sure timer is on -Check for loose or damaged wires
Mechanical timer not working	<ul style="list-style-type: none"> -Make sure trippers are set properly -Make sure that trippers are not pressed against switch at start up, the timer need to rotate a few degrees before the trippers hit the switch -Check for loose or damages wires -Check power supply -Check electrical hook up diagram to ensure correct installation -Check Motor
Digital timer not working	<ul style="list-style-type: none"> -Check timer settings -Make sure current date and time are correct -Make sure power cords are properly connected -Check fuse on main PC board (F3) -Check Power Supply -Check Motor

Mass Flow Controller not working	<ul style="list-style-type: none"> -Make sure timer is on -Check Motor/Motor brushes -Make sure 8 amp breaker is not popped -Make sure flow probe is installed correctly -Check all electrical connections -Check power supply
Elapsed Time Indicator not working	<ul style="list-style-type: none"> -Check Power Supply -Check electrical connections
Voltage Variator with ETI not working	<ul style="list-style-type: none"> -Check Power Supply -Check Electrical Connections -Check Motor
Flow Rate Too Low	<ul style="list-style-type: none"> -Check for leaks -Check filter media placement -Ensure only one piece of filter paper is installed -Check Flow Controller -Check flow valve(TE-1000PUF samplers only) -Ensure proper voltage is being supplied -Check calibration
Chart Recorder not working	<ul style="list-style-type: none"> -Replace pen point -Make sure pen point is touching chart -Make sure pen point is on "0" -Make sure tubing from motor is in place -Check Power Supply -Check motor
Air Leaks	<ul style="list-style-type: none"> -Make sure all gaskets are in place -Make sure all connections are secure -Makes sure connections are not over tightened -Check for damaged components: Filter holder screen, gaskets, motor flanges

Maintenance and Care

A regular maintenance schedule will allow a monitoring network to operate for longer periods of time without system failure. Our customers may find that the adjustments in routine maintenance frequencies are necessary due to the operational demands on their sampler(s). We recommend that the following cleaning and maintenance activities be observed until a stable operating history of the sampler has been established.

TE-1000BL PUF

1. Make sure all gaskets (including motor cushion) are in good shape and that they seal properly.
2. The power cords should be checked for good connections and for cracks (replace if necessary).

CAUTION: DO NOT allow power cord or outlets to be immersed in water!

3. Inspect the filter screen and remove any foreign deposits.
4. Inspect the filter holder frame gasket each sample period and make sure of an airtight seal.
5. Make sure elapsed time indicator is working properly.

Warranty

Instruments manufactured by Tisch Environmental, Inc. are guaranteed by warranty to be free of defects in materials and workmanship for one year after shipment from Tisch Environmental factories. The liability of Tisch Environmental, Inc. is limited to servicing or replacing any defective part of any instrument returned to the factory by the original purchaser. All service traceable to defects in original material or workmanship is considered warranty service and is performed free of charge. The expense of warranty shipping charges to and from our factory will be borne by Tisch Environmental. Service performed to rectify an instrument malfunction caused by abuse, acts of god or neglect, and service performed after the one-year warranty period will be charged to the customer at the current prices for labor, parts, and transportation. Brush-type and brushless motors will carry a warranty as far as the original manufacture will pass through its warranty to Tisch Environmental, Inc. The right is reserved to make changes in construction, design specifications, and prices without prior notice.

Assembly Drawings

TE-1002 Particulate/Vapor Module

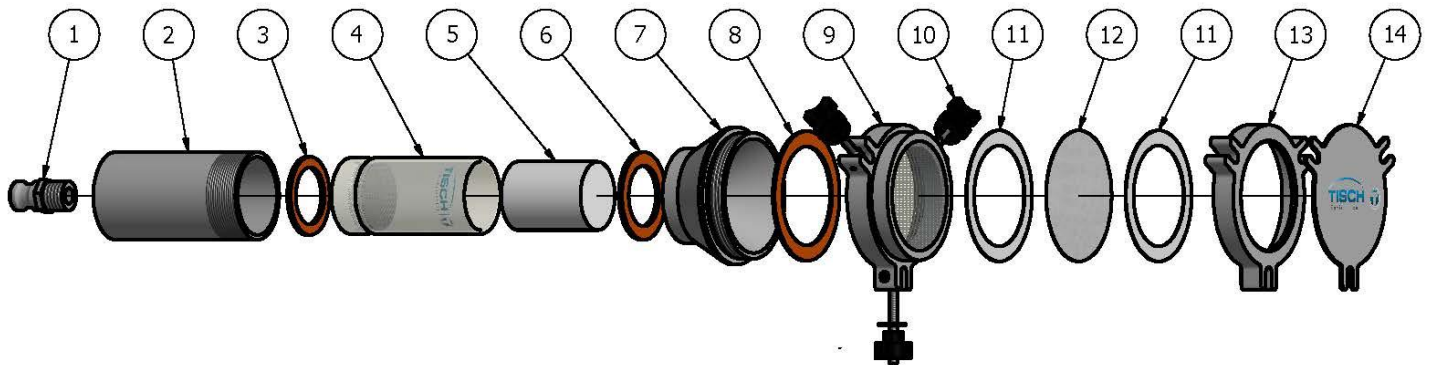

TE-1002 Particulate/Vapor Sampling Module			
ITEM	QTY	PART NUMBER	DESCRIPTION
1	1	TE-1002-4	Module Plug Coupler
2	1	TE-1002-3	Module Body
3	1	TE-1002-8	Lower Module Gasket, Silicone 2 9/16" OD
4	1	TE-1009	Glass Cartridge w/ Stainless Steel Screens
5	1	TE-1010	3" Long Polyurethane Vapor Collection Substrate (Unwashed)
		TE-1011	2" Long Polyurethane Vapor Collection Substrate (Unwashed)
		TE-1012	1" Long Polyurethane Vapor Collection Substrate (Unwashed)
6	1	TE-1002-6	Upper Module Gasket, Silicone 2 7/8" OD
7	1	TE-1002-2	Module Reducer
8	1	TE-1008-8	Filter Holder Gasket, Silicone 4 1/2" OD
9	1	TE-1008-2	4" Filter Holder Body w/ Stainless Steel Screens
10	3	TE-1002-14	Plastic Thumb Nut, Brass Bolt, Washer, and S/S Bolt
11	2	TE-1008-5	Teflon Gasket
12	1	TE-QMA4	Micro-Quartz Filter Media 4" Round for PUF
13	1	TE-1008-1	4" Hold Down Frame
14	1	TE-1008-9	Aluminum Cover for 4" Filter Holder

TE-1004-BL Blower Motor Assembly

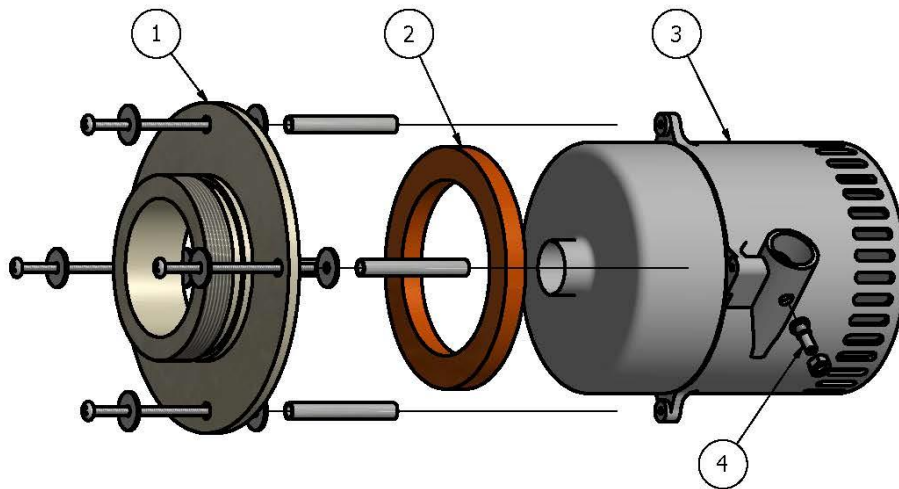

TE-1004BL Assembly			
ITEM	QTY	PART NUMBER	DESCRIPTION
1	1	TE-1004-1	Blower Motor Flange
2	1	TE-5005-4S	Motor Cushion, Silicone
3	1	TE-117417 TE-117415	Brushless Motor for 110V Blower Brushless Motor for 220V Blower
4	1	TE-5005-8BL	Pressure Tap

Calibrator Certificate



TISCH ENVIRONMENTAL, INC.
 145 SOUTH MIAMI AVE
 VILLAGE OF CLEVELAND, OH
 45002
 513.467.9000
 877.263.7610 TOLL FREE
 513.467.9009 FAX

ORIFICE TRANSFER STANDARD CERTIFICATION WORKSHEET TE-5040A

Date - May 04, 2015 Rootmeter S/N 0438320 Ta (K) - 294
 Operator Jim Tisch Orifice I.D. - 2959 Pa (mm) - 755.65

PLATE OR VDC #	VOLUME START (m3)	VOLUME STOP (m3)	DIFF VOLUME (m3)	DIFF TIME (min)	METER	ORFICE
					DIFF Hg (mm)	DIFF H2O (in.)
1	NA	NA	1.00	6.7000	3.6	2.00
2	NA	NA	1.00	4.1130	10.0	5.50
3	NA	NA	1.00	3.2710	15.5	8.50
4	NA	NA	1.00	2.8040	21.0	11.50
5	NA	NA	1.00	2.4730	26.5	14.50
6	NA	NA	1.00	2.3050	30.2	16.50

DATA TABULATION

Vstd	(x axis) Qstd	(y axis)	Va	(x axis) Qa	(y axis)
1.0029	0.1496	1.4197	0.9951	0.1485	0.8821
0.9944	0.2417	2.3543	0.9867	0.2399	1.4628
0.9871	0.3017	2.9268	0.9794	0.2994	1.8185
0.9797	0.3494	3.4044	0.9721	0.3467	2.1153
0.9724	0.3932	3.8227	0.9649	0.3901	2.3752
0.9675	0.4197	4.0778	0.9600	0.4165	2.5337
Qstd slope (m) =		9.82823	Qa slope (m) =		6.15427
intercept (b) =		-0.03871	intercept (b) =		-0.02405
coefficient (r) =		0.99988	coefficient (r) =		0.99988
y axis = SQRT[H2O (Pa/760) (298/Ta)]			y axis = SQRT[H2O (Ta/Pa)]		

CALCULATIONS

$$Vstd = \text{Diff. Vol} [(Pa - \text{Diff. Hg}) / 760] (298 / Ta)$$

$$Qstd = Vstd / \text{Time}$$

$$Va = \text{Diff Vol} [(Pa - \text{Diff Hg}) / Pa]$$

$$Qa = Va / \text{Time}$$

For subsequent flow rate calculations:

$$Qstd = 1/m \{ [\text{SQRT}(\text{H2O}(\text{Pa}/760)(298/\text{Ta}))] - b \}$$

$$Qa = 1/m \{ [\text{SQRT}(\text{H2O}(\text{Ta}/\text{Pa}))] - b \}$$

Calibration Worksheet



TE-1000 PUF Calibration Worksheet

Site Information

Location: Cleveland, Oh:	Site ID: 145	Date: 1-Jul-15
Sampler: TE-1000	Serial No: 1116	Tech: Jim Tisch

Site Conditions

Barometric Pressure (in Hg):	29.80	Corrected Pressure (mm Hg):	756.9
Temperature (deg F):	71.0	Temperature (deg K):	294.8
Average Pressure (in Hg):	29.58	Corrected Average Pressure (mm Hg):	751.3
Average Temperature (deg F):	68.0	Average Temperature (deg K):	293.2

Calibration Orifice

Make: Tisch	Qstd Slope: 9.82823
Model: TE-5040A	Qstd Intercept: -0.03871
Serial#: 2959	Calibration Due Date: 4-Apr-16

Calibration Information

Plate or Test #	Pressure (in H ₂ O)	Qstd (m ³ /min)	Flow (magn)	Flow (corrected)	Linear Regression
1	7.50	0.284	70.0	8.39	Slope: 35.3693
2	6.60	0.266	60.0	7.77	Intercept: -1.6711
3	5.75	0.249	50.0	7.09	Corr. Coeff: 0.9978
4	4.90	0.230	40.0	6.35	
5	3.70	0.200	30.0	5.50	# of Observations: 5

Calculations

$$Qstd = 1/m[\text{Sqrt}((H_2O)(P_a/760)(298/T_a))-b]$$

$$\text{Flow (corrected)} = \text{Sqrt}((\text{magn})(P_a/P_{std})(T_{std}/T_a))$$

m = sampler slope
 b = sampler intercept
 (magn) = magnehelic reading
 Tav = daily average temperature
 Pav = daily average pressure

Qstd = standard flow rate
 Flow (magn) = reading from magnehelic gauge
 Flow (corrected) = corrected flow rate
 m = calibrator Qstd slope
 b = calibrator Qstd intercept
 Ta = actual temperature during calibration (deg K)
 Pa = actual pressure during calibration (mm Hg)
 Tstd = 298 deg K
 Pstd = 760 mm Hg
 For subsequent calculation of sampler flow:
 $Qstd = 1/m[\text{Sqrt}((H_2O)(P_a/760)(298/T_a))-b]$

Average Flow (magn):	36.0
Average Flow Over Sample (m ³ /min)	0.217306
Enter Total Time (hrs):	23.9
Total Flow Over Sample (m ³ /min)	311.6161029
Total Flow Over Sample (LPM)	311616.1029

NOTE: Ensure calibration orifice has been certified within 12 months of use